

**STW YA5 CLCVR
SS Steering
Column Cover**



Please wear appropriate eye protection!

Once the steering wheel is removed wrap the O.E.M. column with 6 to 8 wraps of Super 33+ Scotch electrical tape. The wrap only needs to be at the top of the column. This will allow the new column cover to fit snugly to prevent any sort of rattle. Note: the tape can be any similar type, just as long as it sticks well and shims the column. A bottom wrap can be done if you wish.



Installed and centered you can now install the steering wheel.

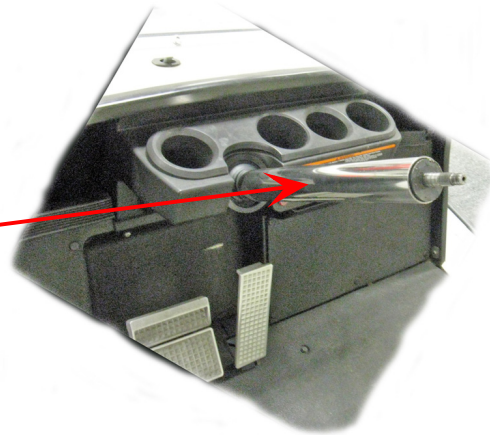

Buggies Unlimited - Tech Tips

Steering Wheel Removal



BUGGIES
UNLIMITED

Steering Wheel Removal

1. Remove the steering wheel by first removing the cover, then loosening the shaft nut but do not remove it.

NOTE: Leave the nut in place until the steering wheel is freed from the steering shaft. If the nut is removed, the steering wheel could injure you when it pops free.

2. Place your knees and arms under the steering wheel and brace your feet on the dash and rock the steering wheel back and forth (with great force) while pulling and pushing upward. In the rare occurrence the steering wheel will not come loose with this method, a puller (**Part #BU102061201**) will need to be used.

Steering Wheel Installation

1. Install the steering wheel onto the steering shaft, but do not install the nut.
2. Drive vehicle to determine if the wheel is correctly centered. if not, stop, reset the position and drive again to verify it is centered.
3. Install and tighten the steering wheel nut to 14 to 16 lbs.. **DO NOT OVERTIGHTEN!** Once a steering wheel has been overtightened, it is often destroyed trying to remove it again later.
4. Replace cover.

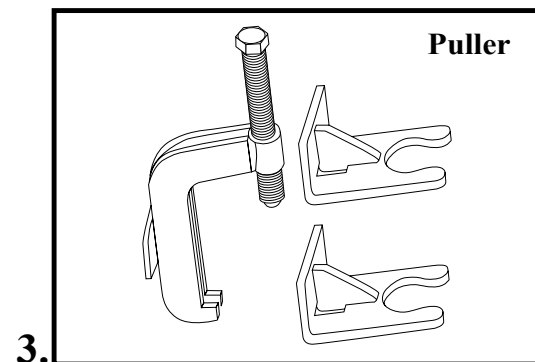

Caution: Wear the appropriate eye protection!



Buggies Unlimited
888-444-9994
buggiesunlimited.com

© Copyright 1997-2008 Buggies Unlimited. All Rights Reserved.