

**E-Z-GO Marathon 4" Axle Lift
1989-1994.5 Electric Models
Installation Instructions
Part# 6201**



A. REAR SPRING RISERS	2
B. 3/8" NUTS FOR SHOCK MOUNTS	2
C. U-BOLTS	4
D. FRONT AXLE	1
E. STEERING RISER	1
F. 1 1/2" X 3/8", 2" X 3/8" WITH LOCK NUTS (FOR FRONT)	1
G. WARNING LABEL	1
H. 2" X 3/8" WITH LOCK NUTS (FOR REAR)	8

 *Always wear appropriate
eye protection!*

FRONT INSTALLATION

1. Jack up the front end of the cart and place it on jack stands. You will be installing larger wheels and tires so raise the cart high enough to accommodate for the additional height.
2. Remove the tie rod joints from the spindles.
3. Remove the spindles from the front axle. Clean and lubricate these bolts for the reinstallation of the spindles.
4. Remove the front axle. Clean and lubricate these bolts for the new axle.
5. Using the bolts from the old axle install JAKES front axle (Item C).
6. Reinstall the spindles to JAKES axle.

7. Install JAKES steering riser (Item D) to the spindle on the passenger side of the cart. (NOTE: On some models you may need to grind both sides of the spindle for this to fit.) The 1 ½ bolt (Item E) goes through the existing hole in the spindle. The 2" bolt (Item E) goes through the remaining hole in the extension. (NOTE: The 2" bolt must be installed with the head toward the tire.)
8. Attach the steering rod end to JAKES steering extension.
9. Reattach the tie rods to the spindles.
10. Securely tighten all bolts.
11. Install JAKES recommended wheel and tire size 22 x 11 x 10 wheels and tires with a 3x5" offset for maximum performance. **NOTE:** Your stock wheels and tires will work but are **not** recommended!
12. Take the cart off of the jack stands and lower the cart.
13. Drive the cart forward 10-20 feet and check the toe-in. (Proper toe-in should be approximately 1/8" in.).

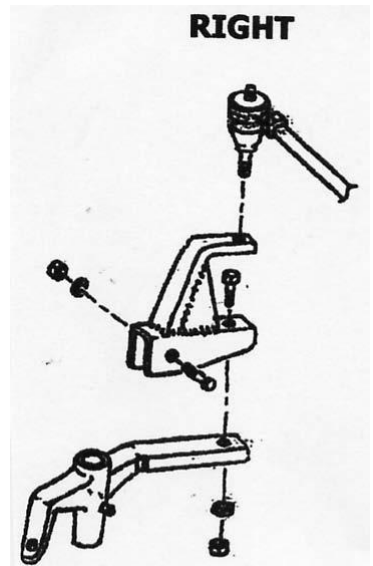

REAR INSTALLATION

1. Jack up the rear end of the cart and place jack stands on the frame in front of the springs. Place a car jack under the rear-end housing. You will be installing larger wheels and tires so raise the cart high enough to accommodate the additional height.
2. Remove the wheels and tires.
3. Remove the bottom shock bolts and discard.
4. Unbolt the rear leaf springs from the cart. Using the car jack lower the axle.
5. Loosely mount Jake's rear spring risers (Item A) to the axle using with the supplied u-bolts (Item C) with the 3/8" bolt for the shocks on top and pointing towards the center of the cart.
6. Place the leaf springs on top of the new spring risers. Loosely bolt the leaf springs to the stock front leaf spring mounts using the stock hardware. Using the supplied 3/8 x 2 bolts and locknuts (Item H) and stock spring mount loosely bolt the leaf springs to the new spring risers as shown below. Loosely mount the rear of the leaf spring to the stock leaf spring mount using the stock hardware. Once both leaf springs are loosely mounted and in place securely tighten.
7. Attach the bottom of the shocks to JAKES rear spring risers with the provided lock nuts (Item B.)
8. Install JAKES recommended wheel and tire size 22 x 11 x 10 wheels and tires with a 3x5" offset for maximum performance. **NOTE:** Your stock wheels and tires will work but are **not** recommended!
8. Included is a warning instruction (Item G) which is to be placed on the steering column or another visible area and is to be read by all operators.
9. Double check all nuts and bolts for tightness.

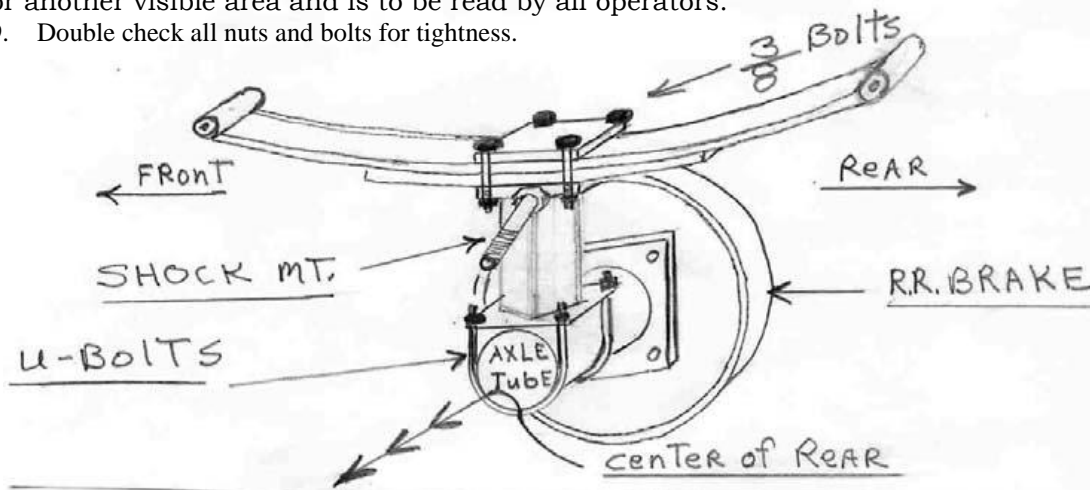

Indemnification And Insurance Agreement

High Performance Enhancement Kit purchaser assumes sole and entire responsibility for, and shall indemnify and save harmless Nivel LLC, from any and all claim, liability, responsibility, and persons or property that may be sustained in connection with the use of any product before or after purchase, including but not limited to high performance enhancement lift kits. The High Performance Enhancement Kit purchaser also shall indemnify Nivel LLC harmless with respect to any and all liability that may be incurred.

Golf Cars are recommended for use only by those aged 16 and older. Golf Cars can be especially hazardous to operate. Always remember that riding and alcohol/drugs don't mix. Never ride on public roads. Never carry more than two passengers (except shuttles and trams). Never engage in stunt driving. Avoid excessive speeds and be particularly careful on difficult terrain. Nivel LLC reserves the right, at any time, to discontinue or change specifications, prices, designs, features, models, or equipment without notice and without incurring any obligation.



866-405-2537

www.jakesliftkits.com



Copyright Nivel LLC
All Rights Reserved